

SAMICK PIANO

Upright and Grand piano



58-3, Nonhyeon-dong, Gangnam-gu, Seoul, KOREA / TEL +82-70-7931-0665 FAX +82-70-7931-0604 E-mail info@samick.co.kr
www.smcmusic.com

Specifications are subject to change without notice.



WSU series ----- P. 4

JS series ----- P. 8

Dream System ----- P.16

NSG series ----- P. 20

SIG series ----- P. 24

Samick History ----- P. 26



The Ultimate in Musical Expression

Through the centuries the piano has acquired a central place in the music world which stays unequalled. The piano is able to convey every nuance of emotion and is unparalleled in beauty and dynamic musical expression. The manufacturing of a great piano starts with the determination with avoiding any compromises regarding the materials, the craftsmanship and the design. Countless pieces of selected materials are individually

handcrafted into a precision instrument capable to translate the most subtle expressions of the soul into the language of music. Creating each instrument with a harmonious blend of the best traditional craftsmanship and advanced technology SAMICK Piano will fulfill all your desires and will bring your musical sense into the next plane.



About SAMICK MUSICAL Instruments Co., Ltd

Established in 1958 with the founding spirit that nurturing the instrument industry in Korea will benefit the nation, SAMICK MUSICAL Instruments Co., Ltd has considerably expanded and became one of the world-biggest piano manufactures and exporters' world wide. SAMICK was also able to take a major position as the best maker of various music instruments. In the half past century SAMICK found the way and became a true global company, in collaboration with 200 partners in 80

countries world wide. The instruction of advanced technologies into the piano production with the added production bases and drastic overseas marketing strategies SAMICK is confirming his global position as one of the great piano manufacturers. SAMICK will continue to produce the best masterpieces in the world, customer-oriented and putting all his efforts on endless researches and developments regarding quality, innovation and design.

WSU Series

The WSU Series can be nominated as the starting instrument for professional pianists enjoying elegant performances. Crafted from the finest materials and excellently designed this piano is maintaining the traditional shape and will complete an interior with class. The World Series action and keyboard precision that play along with speeding strikes of the key will for sure put you into trance.

Excellence in piano making begins with the careful selection of the materials directly involved in producing sound



Abel-Hammer

To produce a distinct, clear tone, the WUS series use ABEL hammer from the world's leading manufacturer for this equipment in Germany.

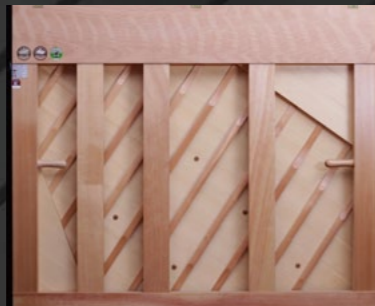

Double sound board

The double soundboard produces the characteristic warm rich tone now known as the "special European sound".

Samick's commitment to sound quality shows in details

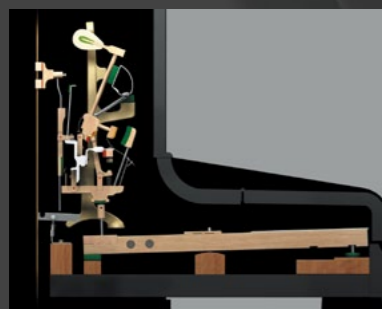

Sostenuto

The Sostenuto system reserved in the past to the grand pianos only, is now workable and built into the WSU series, enabling to sustain individual sounds.



Slow-Closing Fallboard

WSU Series have conceived a damping and intelligent unit enables to prevent any accidents which could critically injure the hands.

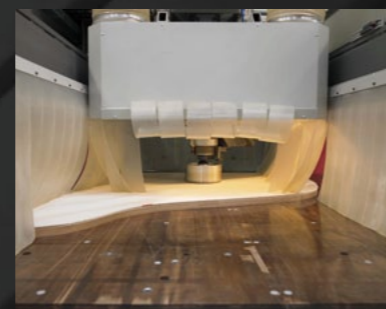

CNC-Computer Numerical Control

By the application of piano engineering technology, WSU series ensure high accuracy manufacturing and transparent distinctions in sound.



Upright Piano WSU 132ME

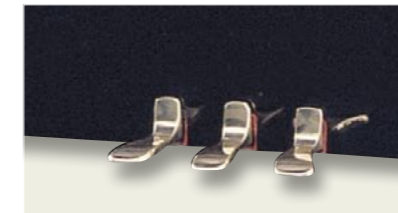

- Tapered premium grade solid spruce Soundboard, Laminated solid spruce Backposts
- Sand-casting Iron plate Frame
- Ebony black keys, slow closing system Fallboard
- Sostenuto unit for sophisticated pianists
- Double sound board
- Abel hammer
- Brass Caster
- Die casting pedal

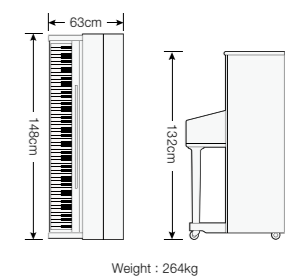

Upright Piano
WSU 132CF



- Tapered premium grade solid spruce Soundboard, Laminated solid spruce Backposts
- Sand-casting Iron plate Frame
- Ebony black keys, slow closing system Fallboard
- Sostenuto unit for sophisticated pianists
- Double sound board
- Abel hammer
- Brass Caster
- Die casting pedal

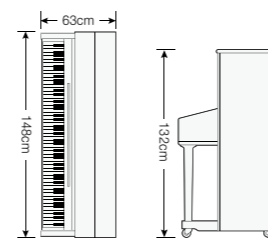

Weight : 264kg

Upright Piano
WSU 122ME

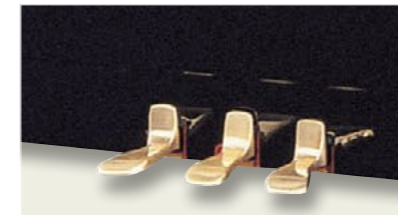
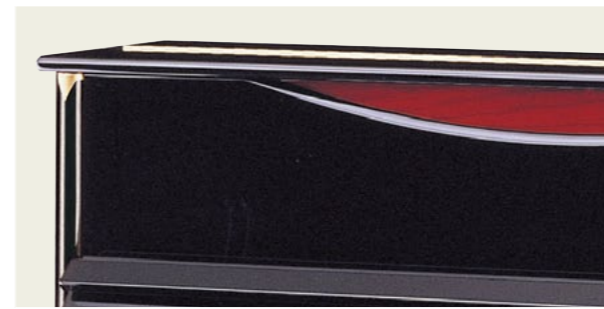

- Tapered premium grade solid spruce Soundboard, Laminated solid spruce Backposts
- Sand-casting Iron plate Frame
- Ebony black keys, slow closing system Fallboard
- Sostenuto unit for sophisticated pianists
- Double sound board
- FFW hammer
- Brass Caster
- Die casting pedal

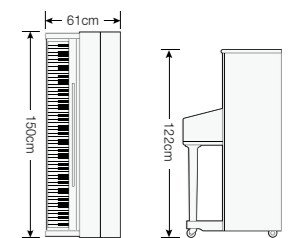

Weight : 221kg

JS Series

A respected choice among musical professionals and students, today's JS Series are better than ever.

JS Series are much more than an assembly of manufactured pieces with the help of the modern technology. Nothing can replace the subtlety, the musical sensibility and the precision of the piano makers-ear. There is a kind of inside soul in JS series which reveal some secrets behind the tones.



FFW hammer

High Quality hammer felts from German FILZFABRIK WURZEN GmbH and stable muffler assembly will increase the quality of your performances and your professionalism.



Slow-Closing Fallboard

JS series have conceived a damping and intelligent unit enables to prevent any accidents which could critically injure the hands.

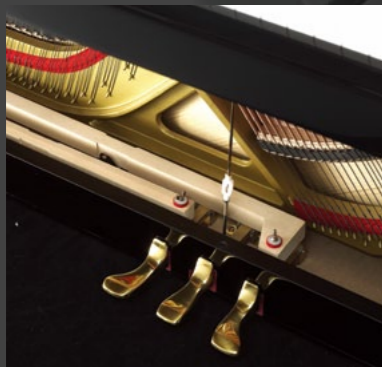

Stong Levers in Wood

The most stable JS series' pedal assembly with strong levers in woods will enrich your playing.



The Finest materials

The JS series are authentic instruments and pieces of art, all components are designed to form exceptional works. Composed of over 8.000 of parts, like precious wood, finest steels and leathers to felts, all in the highest quality and precision to create world class pianos able to provide superb sounds.

Original JS

Upright Piano

JS 132MD

- Spruce core sound board
- Sand casting Iron plate
- Vertical laminated maple bridge
- Roslau string
- Slow closing system
- Die casting pedal

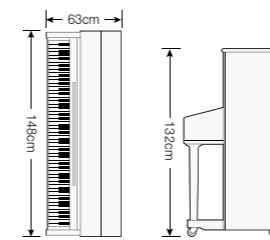

Weight : 260kg

Upright Piano

JS 132FD

- Spruce core sound board
- Sand casting Iron plate
- Vertical laminated maple bridge
- Roslau string
- Slow closing system
- Die casting pedal

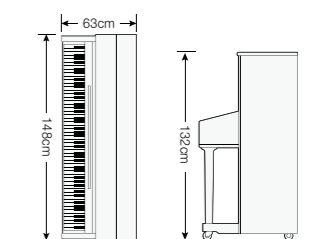

Weight : 260kg

Available Colors



Upright Piano
JS 121MD

- Spruce core sound board
- Sand casting Iron plate
- Vertical laminated maple bridge
- Roslau string
- Slow closing system

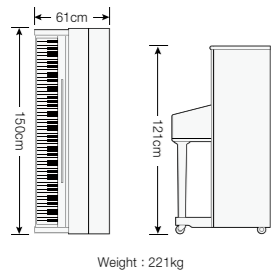

Upright Piano
JS 121FD

- Spruce core sound board
- Sand casting Iron plate
- Vertical laminated maple bridge
- Roslau string
- Slow closing system

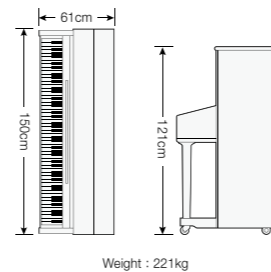

Upright Piano **JS 043**



Upright Piano **JS 115**

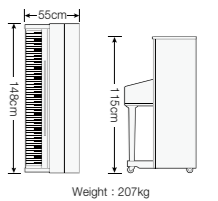
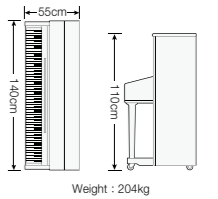

Upright Piano
JS 118

- Spruce core sound board
- Sand casting Iron plate
- Vertical laminated maple bridge
- Roslau string
- Slow closing system

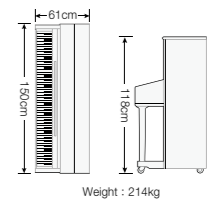

Upright Piano
JS 125

- Spruce core sound board
- Sand casting Iron plate
- Vertical laminated maple bridge
- Roslau string
- Slow closing system
- Die casting pedal

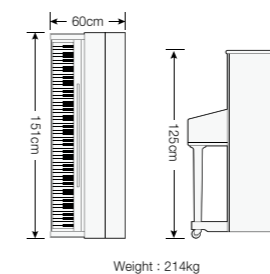

Available Colors

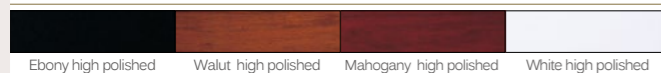

Available Colors





Upright Piano
JS 143F

- Sand casting Iron plate
- Vertical laminated maple bridge
- Roslau string
- Slow closing system

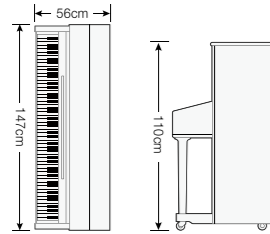

Weight : 202kg



Upright Piano
JS 143M



Upright Piano
JS 143T

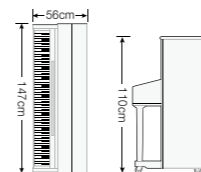

Weight : 202kg

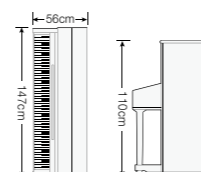

Weight : 202kg

Available Colors

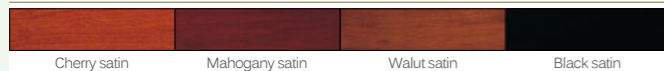

Upright Piano
300NSTD

- Sand casting Iron plate
- Vertical laminated maple bridge
- Roslau string
- Slow closing system

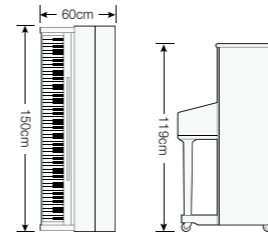

Weight : 214kg



Upright Piano
SHK-1004R

- Sand casting Iron plate
- Vertical laminated maple bridge
- Roslau string
- Slow closing system
- Chrome caster
- Die casting pedal
- Ebony black keys
- FFW hammer

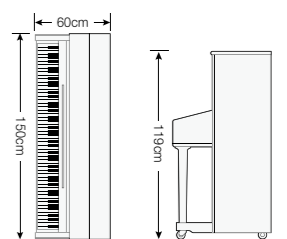

Weight : 214kg



Available Colors

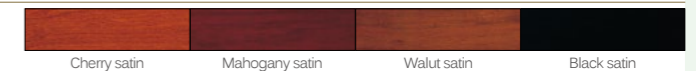



Upright Piano
Anna 110

- Sand casting Iron plate
- Vertical laminated maple bridge
- Roslau string
- Slow closing system
- FFW hammer

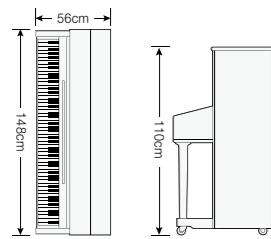

Weight : 203kg

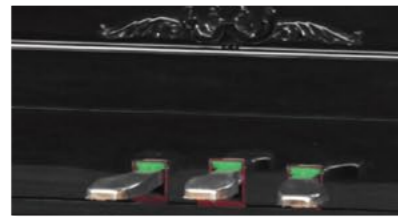

Available Colors

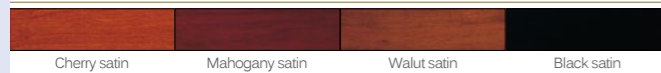

Upright Piano
H 118

- Sand casting Iron plate
- Vertical laminated maple bridge
- Roslau string
- Slow closing system
- FFW hammer
- Die casting pedal

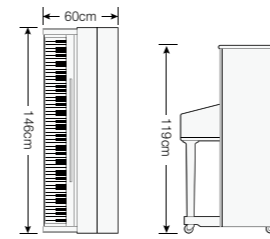

Weight : 226kg



Upright Piano
Ditto

- Sand casting Iron plate
- Vertical laminated maple bridge
- Roslau string
- Slow closing system
- Chrome Caster
- Ebony black keys
- FFW hammer

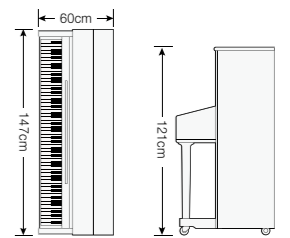

Weight : 220kg

Available Colors

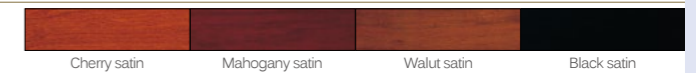

The key to faster learning is DREAM ALL THE TIME.



This is how the Samick Dream features help increase practice times.

1. Extraneous noises and distractions often cause practice times to conclude prematurely.
2. Listening to the same piece of music played over and over again can send some people a little bit crazy. The use of headphones solves this problem, and allows normal conversation to continue in the room.
3. Music is all about timing, and a built-in metronome allows students to practice to the correct time and rhythm.
4. Difficult sections can be recorded and played back through the headphones. The student can hear their mistakes and try to correct them. This process can be repeated until the section has been mastered.
5. MIDI out can be used to connect to a home computer with composition software. This encourages students to compose and print their own music. The MIDI files can also be held on a USB memory stick for later use.

Enjoy the real exquisite SAMICK acoustic piano sound with the feeling to play in a concert hall or in a recording studio

Acoustic Piano



Dream Piano

Your dream with SAMICK piano becomes true at any time



Hammer Shank Stop Rail

Dream piano assures no difference on touch. No deforming and no unnecessary noise, with upper positioned CAM type Hammer.



Handle Lever Pedal

Easy to change soundproof or release by center pedal.



Optical Sensor Strip Rail

This sensing system detects the detailed nuance of key moving. You can express with full range velocity or off-set mode depends on the music and sends MIDI data to other devices or sequencer.



Specifications

- Keyboard Sensor: Optical with 255 calibrations for each note
- Instrumental Sounds: Piano, Church Organ
- GM sounds: An additional 128 General MIDI sounds are available
- Metronome: Tempo/Rhythm/Beat/Volume
- Record and Playback: 30,000 notes
- Demonstration: 10 songs
- MIDI: IN/THRU/OUT
- Sound: IN/OUT (stereo)
- Sustain Pedal: Photo sensor
- Mute Rail: CAM type operated from the piano's center pedal
- Power Supply: DV12V 1500mA

samick 

*From the first moment I felt the music
Samick piano has always been close by
It is... my soul*



NSG Series

The superior features of the New Samick Grand piano series. The detailed sense of touch on the fingertips and the resonance of beautiful sounds inspire the pianist for a performance of unbound expressions. A celebrated masterpiece created from the finest lumber, highest quality parts, and the unmatched skilled of master craftsmen. No longer reserved only for world-class pianists, NSG Series are now available for anyone who wishes to taste the deep and rich sounds of this masterpiece in everyday life. Recognized by professional pianists, now everyone can share the spirit of NSG series.

One Glance, One Touch, Says it All

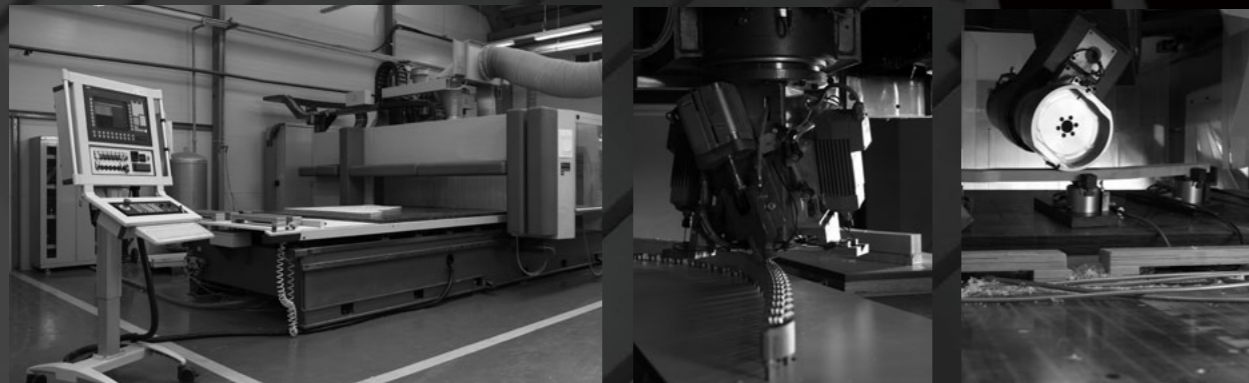

CNC computer Numerical Controlling

As the world's largest manufacturer of grand pianos, SAMICK employs world class craftsmen and technicians with great experience. They combine the most advanced technologies like high automated computer controlled devices (CNC Computer Numerical Controlling) with their traditional handcrafted skills to create instruments of rare quality with the finest touch and tone.

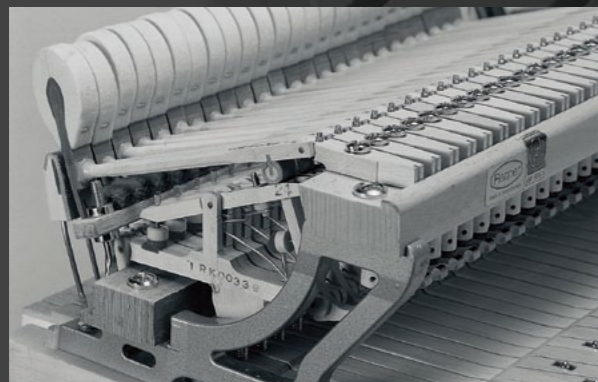

The action. The heartbeat of NSG series

NSG Series are genuine piano making art from, combining over 6,000 parts made of wood, leather, felt and steel to create a smooth-working action. This wonderful piece of work is only possible with the lucky blend of craftsmen's skills and artistic flair, as well as with the steady eye and precise manipulation of the experienced expert.



The scale. The way of measuring tonal culture

The scale, the lengths and diameters of the strings, has a major influence on the tonal culture of a piano. While the work on the complex eased somewhat by specialized computer software, obtaining a balanced and rich quality of tone still takes a great deal of research and experience.

The Concert Grand-Selected for International Competition

NSG 280

NSG SERIES



- CNC Process
- Premium grade solid spruce, seasoned, contoured and tapered sound board
- Ebony Wood Black Key
- Renner action
- Abel Hammer
- Duplex Plate
- Wide Brass roller with locking system
- Multi tone-collector
- Solid spruce back post

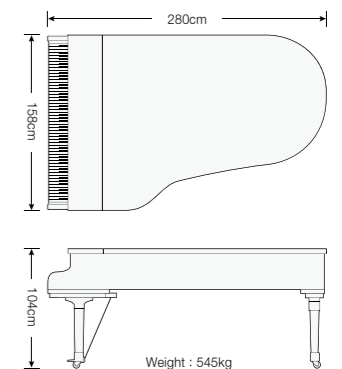



NSG 228

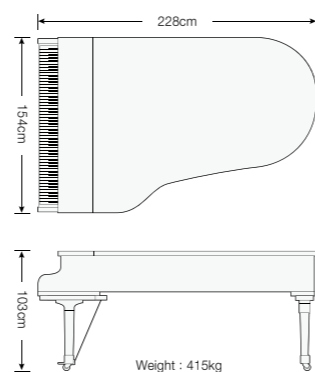

NSG 186

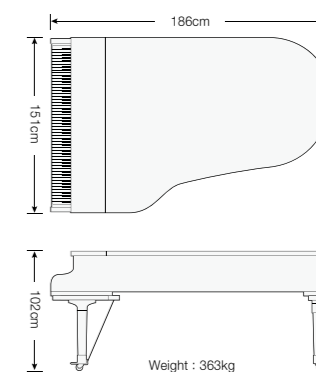

NSG 208

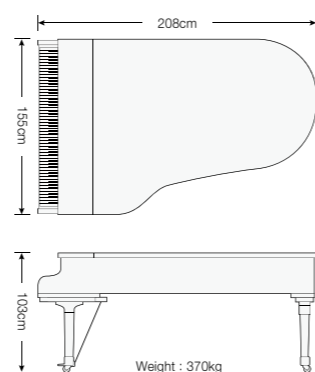

NSG 175



NSG 158



- CNC Process
- Premium grade solid spruce, seasoned, contoured and tapered sound board
- Ebony Wood Black Key
- Seiler action
- Abel Hammer
- Duplex Scale
- Multi tone-collector

- CNC Process
- Premium grade solid spruce, seasoned, contoured and tapered sound board
- Seiler action
- Duplex Scale
- Multi tone-collector

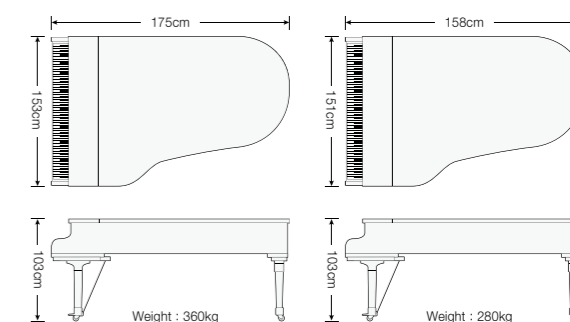

SIG Series

World class materials, components and craftsmanship. Only the materials carefully selected based on our continuous research and development that spends for 60 years are used and conditions required in creating precision, strength, grandeur, and deep and rich sounds have been enhanced. The SIG Series is reserved for pianos created by master craftsmen with deep and intimate knowledge of pianos. Simple body design and high gloss black finish of SIG series complements any type of residential or studio atmosphere.



Using the finest materials for the best sound.

SIG grand pianos are authentic instruments and pieces of art, all components are designed to form exceptional works. Composed of over 8,000 of parts, like precious wood, finest steels and leathers to felts, all in the highest quality and precision to create world class pianos able to provide superb sounds. All those facts and the great blend of craftsmen and artistic flair are the true heirs of the long SAMICK tradition.

Superior Durability and Elasticity of Skeleton

Skeleton is crafted with carefully selected hardwood, in a radial structure Hardwood, and is equipped with Tone Collector for improved structural integrity and superior sound resonance.

Consistent Hammer Quality

SIG's hammers are crafted from A-grade North American maple to be solid inside and out. Hammerheads are precisely arranged in the order from low tone to high tone to maintain uniform string-strike strength. State-of-the-art high frequency pressing technique enhances the hammer's flex, resulting in improved timbre and even tone.

Highly Durable Inner and Outer Rim Materials & Secrets of Soundboard Design

Inner and Outer Rims are manufactured in the optimal ratio of laminated and painted maple and hardwood. They are attached with a high frequency press, it results stable rim formation and superior durability and structural integrity.



Soundboard design: Key to the Secrets of SIG series

SIG series are designed through a 3-dimensional Pro-Crown process and is created with the highest quality spruce to delivery deep and rich sounds and offer detailed resonance characteristics throughout the entire range of sounds it creates.



Available Colors

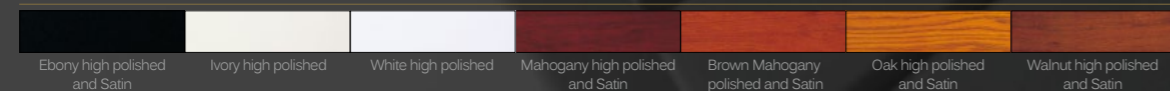

In your music room for good play



SIG 61

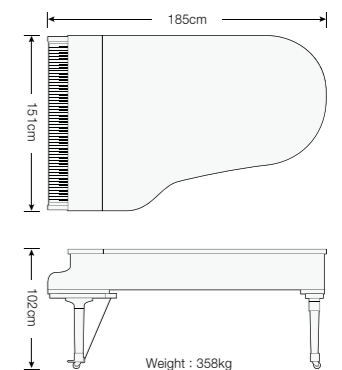

SIG 59



SIG 59L



- Premium grade solid spruce core sound board
- Sand casting Iron plate
- German hammer felt
- Samick Premium action
- Tone collector

Model	Height	Width	Depth	Weight
SIG 61	102cm	151cm	185cm	358kg
SIG 59	103cm	153cm	175cm	360kg
SIG 54	103cm	148cm	161cm	310kg
SIG 50	103cm	149cm	150cm	297kg
SIG 48	99cm	146cm	145cm	277kg

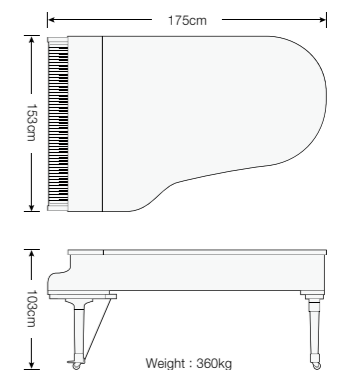

SAMICK



September 1. 1958	Founding of Samick Piano Co. Ltd (Seoul, Korea)
June 29. 1971	Acquiring KS Mark (Piano & Piano Action)
January 20. 1978	Opening US branch office (California, USA)
December 11. 1980	Opening Germany branch office (Dusseldorf, Germany)
July 1. 1987	Establishment of Samick Music Corp (USA)
September 12. 1988	Acquiring JIS Mark (Piano & Piano Action)
September 30. 1988	Listed in Korean Security Exchange Market
February 22. 1989	Acquiring UL mark (Digital Piano)
June 9. 1989	Establishment of Harbin Samick Musical Instrument Co. Ltd (Harbin, CHINA)
March. 2. 1990	Opening Japan branch Office (Tokyo, Japan)
March. 3. 1990	Establishment of PT Samick Indonesia (Bogor, Indonesia)
Septeber 6. 1995	Appointed "World Best Product" by Korea Trade-investment Promotion Agency
December 30. 2002	Acquisition of C.Bechstein Pianofortefabrik AG (Berlin, Germany)
November 12. 2003	Establishment of Berlin Bechstein Shanghai Corp.(Shanghai, China)
December 26. 2005	Establishment of Samick Bechstein Trading Shanghai Corp.(Shanghai, China)
December 29. 2006	Establishment of Samick Japan Co. Ltd (Tokyo, Japan)
July 4. 2007	Establishment of Yichang Saming Musical Instrument (Yichang, China)
November 27. 2008	Acquisition of Seiler pianofortefabrik GMBH (Kitzingen, Germany)
November 5. 2009	Acquiring shares of Steinway Musical Instrument (Messachusetts, USA)
May 3. 2011	Relocation of Head office. Eumsung, Chungbuk, Korea



ArtForte

It means the compound word which is formed from the words "ART" and "FORTE" from pianoforte. This is the Samick's art-project in collaboration with G.A.N.A art center.



Art Forte

Spirit of a great artist

